

CeraClean

- Sample preparation system for on-line Monitors
- Separation of particles, colloids and high-molecular substances

A sample stream of 2 - 4 m³/h is pumped through the CeraClean. The filtrate passes the special filter tube and is pumped to the analyzer. Blockages are minimised by a special cross flow filter, and automatic back-flushing extends the filter life to several weeks between cleaning.

CeraClean is specially designed for low energy consumption and low maintenance costs, which are provided by the automatic cleaning and a small feed pump.



Applications

- Municipal and industrial waste water treatment plants
- Degreasing baths
- Sludge
- Automatic washing installations
- Landfill seepage water

CeraClean removes solids, colloids and high molecular weight interfering substances from dirty samples. The filtrate is lead in the analyzer for continuous monitoring.

In North America:



www.southforkinstruments.com

Advantages

CeraClean advantages compared to other filters:

- Low dead volume gives rapid response time
- Robust construction for long life
- Resistant to strong chemicals
- Long cleaning intervals
- Small installation size
- Low energy consumption
- Low operating costs
- Supplied premounted for easy installation

CeraClean

Technical Data

Number of Moduls

1

Filter Life Cycle

approx. 6 months

Solids separation

Standard filter tube removes solids, colloids and compounds larger than 0.4 µm) Other filter types available (approx. 80 µm for TN/TP)

Sample temperature

> 10 °C - 100 °C

Chemical resistance

pH 1 - 13

Sample pressure

1 - 2 bar

Sample flow rate

min. 2 m³/h, max. 4 m³/h

Filtrate flow rate

at least 1.0 l/h

Ambient temperature

0 - 45 °C

Chemical interval

2 - 8 weeks, depending on sample contamination

Power requirements

97 V - 265 V, 48 Hz - 62 Hz
approx. 70 VA

Dimensions (HxWxD)

1000 x 500 x 240 mm

For further information please contact our technical support

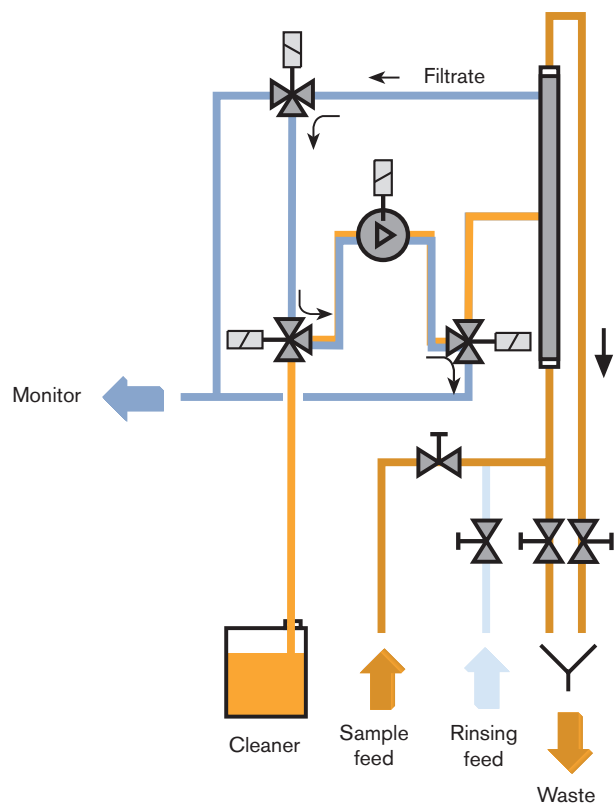

NORTH AMERICA DISTRIBUTION
- ANALYZERS



www.southforkinstruments.com

SPX®

SPX Flow Technology Norderstedt GmbH - Werkstraße 4 - D-22844 Norderstedt
Phone: +49 40 52202-0 Fax: +49 40 52202-444 E-Mail: branluebbe@spx.com

SPX reserves the right to incorporate our latest design and material changes without notice or obligations.

Design features, materials of construction and dimensional data, as described in this bulletin, are provided for your information only and should not be relied upon unless confirmed in writing. Please contact your local sales representative for product availability in your region. For more information visit www.spx.com.

"The green ">" is a trademark of SPX Corporation, Inc."