

ECI-02 Communication Interface



- » Standardized dimensions for DIN rail mounting
- » Galvanically isolated power supply for sensor
- » RS485 interface (galvanically isolated)
- » Compact design

The Exner Communication Interface ECI-02 ensures the safe transfer of the Modbus signal to a standardised RS485 interface and an optimal power supply for the connected sensor.

Specifications

Housing:	DIN rail housing 23 mm
Power supply:	24 V DC (12 ... 36 V DC)
Output:	Modbus RS485
Input:	Sensor EXcell
Accessories:	Connection cable 2m / 5m

Dimensions

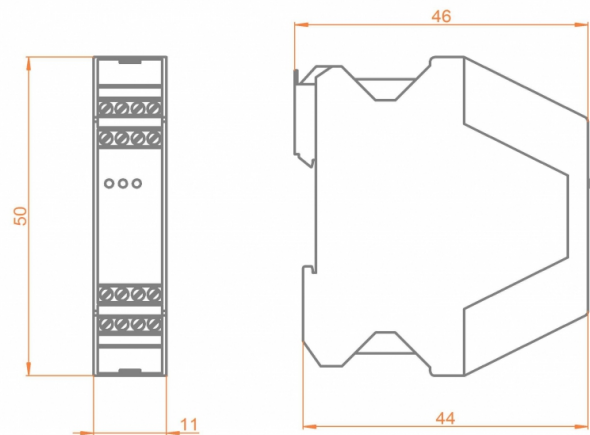

Contact:



www.southforkinstruments.com

Tel: 925 461 5059