

EXspect 231

TECHNICAL INFORMATION

NIR - Absorption Sensor



All brand and product names are trademarks of the company:

EXNER PROCESS EQUIPMENT GmbH

Imprint

7 0

Contact:

Distributed by:

Exner Process Equipment GmbH

Carl-Metz-Str. 26

D-76275 Ettlingen



www.southforkinstruments.com

Tel: 925 461 5059

Date of issue: 2022-05-23

As per: 11.03.2022

File: EXspect 231 TI en 220311

© 2020, Dipl.-Ing. [Graduate Engineer] Detlef Exner

All rights reserved, including the translation.

The reproduction of the content in these operating instructions is subject to prior written approval by EXNER PROCESS EQUIPMENT GMBH, ETTLINGEN.

All technical information, drawings, etc. is subject to the protection of copyright law.

Technical modifications reserved.

Printed on chlorine-free and acid-free pulp paper.

Table of contents

1	Technical data	4
1.1	Standards	4
1.2	Specifications	4
1.3	Dimensions	5
1.4	Environmental conditions	6
1.5	EXspect process conditions	6
1.6	Identification plate	6
2	Product description	7
2.1	NIR - Absorption Sensor EXspect 231	7
2.1.1	Components	7
2.2	Function	9
2.3	Process integration	11
2.4	Checking and adjustment	14
3	EXspect 231 order structure	16
4	Spare parts and accessories	17
4.1	Certificates	17
4.2	Factory inspection	17
4.3	Spare parts	17
4.4	Installation adapters	18
4.5	Weld-in pipe with adapter G 1/2"	19
5	Certificates and compliances	21

1 Technical data

1.1 Standards

The following standards were applied when manufacturing the sensor:

- EN 61326-1: 2013-7
- EN 61326-2-3: 2013-7
- DIN/EN 27027 (ISO 7027)

1.2 Specifications

Sensor specifications	
Measurement range	Version A: 0...100 % absorption Version B: 0...3.5 AU / 0...3850 EBC / 0...7 OD Version C: 0...6 AU / 0...6600 EBC / 0...12 OD
Resolution	0,1 % or 0,01 AU
Accuracy	± 1 %
Reproducibility	≤ 1 % from final value
Wave length	850 nm
Light source	LED
Material	Stainless steel 1.4435 (316L)
Surface finish	Electropolished Ra <0.37 µm
Measuring window	Sapphire
Supply voltage	24 V DC
Output current	4...20 mA
Switch output	Can be set to NO or NC
Input contact	+24 V DC for calibrating (zeroing)
Cable connection	5 or 8-pin M12 plug
Cable length	2 m or 5 m
Process connection	G ½" for welding sockets with 35° cone

Maximum measurement range for Version B:

Unit	Optical path length		
	5 mm	10 mm	20 mm
AU	0...3.5	0...3.5	0...3.5
OD	0...7	0...3.5	0...1.75
EBC	0...3850	0...1920	0...960

Maximum measurement range for Version C:

Unit	Optical path length		
	5 mm	10 mm	20 mm
AU	0...6	0...6	0...6
OD	0...12	0...6	0...3
EBC	0...6600	0...3300	0...1650

1.3 Dimensions

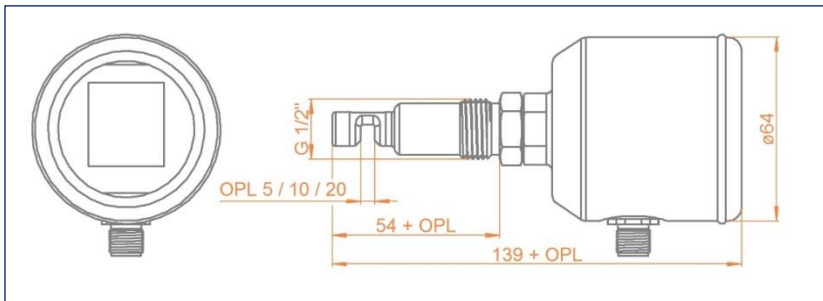

Fig. 1: Sensor dimensions

1.4 Environmental conditions

Ambient temperature: -10...70 °C

Transport and storage temperature: -20...80 °C

1.5 EXspect process conditions

Max. permissible pressure PS: 10 bar

Max. permissible temperature TS: 90 °C

Max. permissible sterilisation temperature 135 °C max. 1 hour

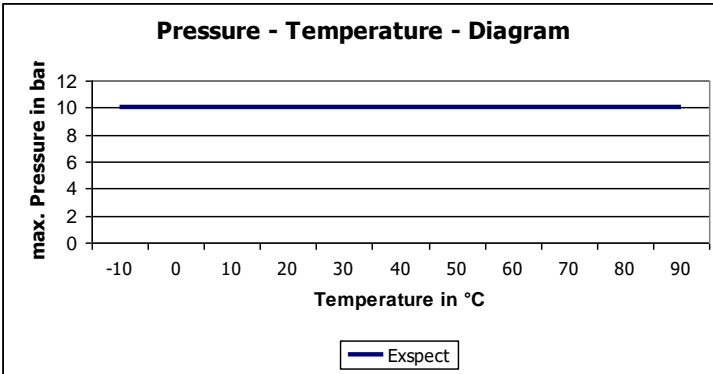

Fig. 2: EXspect 231 pressure-temperature diagram

1.6 Identification plate



Fig. 3: Identification plate

2 Product description

2.1 NIR - Absorption Sensor EXspect 231

2.1.1 Components



1	Housing cover
2	Touch display
3	M12 port
4	Pressure screw
5	Process connection
6	Measuring window

Fig. 1: NIR - absorption sensor

EXspect 231

The EXspect 231 NIR absorption sensor is a 180° transmitted light sensor in the near-infrared range (wavelength of 850 nm), which measures the absorption of fluids. The sensor is designed to monitor continuous process results or to display changes reliably. It is particularly suitable for phase separation, controlling separators, filter monitoring and measuring concentrations.

- Reliable phase separation
- Quicker product changeovers
- Reduced waste water costs
- Filter monitoring
- Colour-independent concentration measurement
- Compact design with integrated booster and display
- Durable sapphire windows
- Hygienic design, suitable for CIP

- LED light source, guaranteed stable and long-lasting signal
- Integrated contact and analogue output
- Easy parameterisation

Measurement range

The measuring range of EXspect 231 sensors is related to the various units of measure and sensor designs as follows:

EXspect 231 Design "A":

0...100 % Absorption

EXspect 231 Design "B":

0...3.5 AU Absorption unit

0...3.850 EBC European Brewery Convention

0...15.400 FAU Formazine absorption unit

0...31.570 mg/l Milligrams per litre of dry substance (Reference: Formazine)

The maximum measuring range is dependent on the selected optical path length.

EXspect 231 Design "C"

0...6 AU Absorption unit

0...6.600 EBC European Brewery Convention

0...26,400 FAU Formazine absorption unit

0...26.400 TEF Formazine turbidity unit

0...54.120 mg/l Milligrams per litre of dry substance (Reference: Formazine)

The maximum measuring range is dependent on the selected optical path length.

Display

The current measurement value is shown on the display. The sensor can be configured using the touch display.

Calibration input

The current measurement value can be set to 0 by briefly connecting a 24 V DC signal to the calibration input. With this, the transmitter can be adjusted to familiar measurement media (zeroed). The same is possible using the "Offset Val" menu function.

2.2 Function

Measuring unit

Defines the measuring unit to be displayed. Various units can be selected depending on the sensor design. For absorption measurements, you can choose between AU (**absorption unit**) and a self-defined free measurement, a CDU (**customer-defined unit**). Other units available include:

EBC	E uropean B rewery C onvention
FAU	F ormazine a bsorption u nit
TEF	turbidity unit Formazine – german: T rübung e inheit F ormazin
mg/l	m illigrams per litre

The following is valid for measurement in Formazine: 1 FAU = 1 FTU = 0.25 EBC = 2.05 mg/l

NOTE

The measurement unit CDU which can be defined individually is only available for sensor versions B and C.

Zeroing

Set the current measurement value to 0 by using Offset. The same function as the input adjustment function via the external contact.

Display toggling

Defines which measurement value should be displayed:

- Absorption
- Customer-defined unit (CDU)

The factory pre-set CDU value can only be changed or adjusted for sensors with the 8-pin M12 connector and with the ECI-01 communication interface, as well as the EXpert 2.x software.

Regardless of the display toggling, the analogue output always provides an absorption-dependent signal.

Lower measuring range

Defines the 4 mA point for the output current. You can choose from a range of 0...100 % of the possible measuring range.

Upper measuring range

Defines the 20 mA point for the output current. You can choose from a range of 0... 100 % of the possible measuring range.

Damping

Attenuates the measurement value through a flowing averaging process.

Switch-off point

Defines the point at which the contact switch switched off. The range can be freely selected between 0...100 %.

Switch-on point

Defines the point at which the contact switch is activated. The range can be freely selected between 0...100 %.

Switch function

Defines the digital output function for the contact switch. You can choose between making contact and breaking contact.

Switching delay

Defines the switch delay for the contact switch. You can choose freely from a range of 0... 200 seconds.

Language

Defines the display language.

2.3 Process integration

Sensor

The EXspect 231 sensor is integrated directly into pipes or tanks with its G 1/2" connector, or by using corresponding adapters with the existing process connectors.

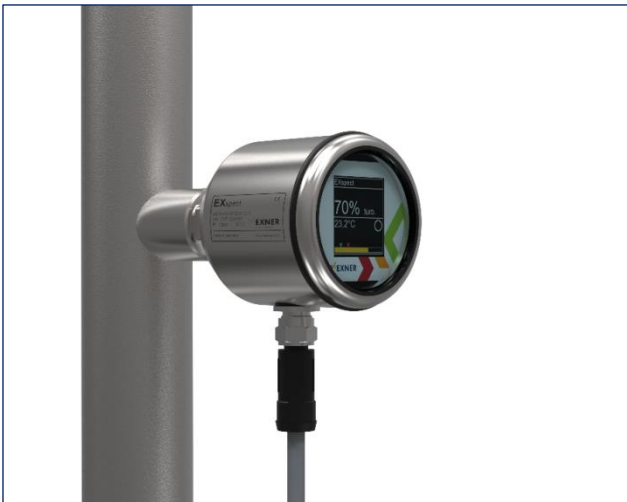
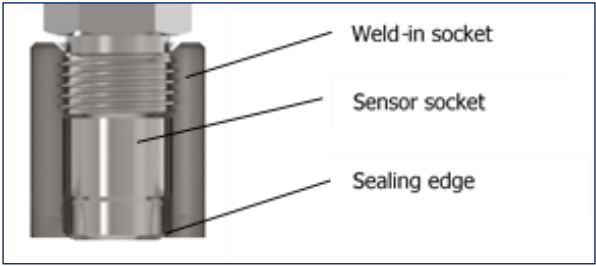

Fig. 5: Process integration

Welding sockets

Installation using welding sockets guarantees hygienic process adaptation, which can be used without dead space and free of elastomers. As this is a purely metal-sealed system, no other sealing materials, e.g. elastomers, may be used.



Please always use the weld-in plugs supplied so that the heat resulting from the welding process can be dissipated safely, and to effectively prevent the drill hole from becoming distorted.



Welding in tanks / pipes

1. Drill a hole with the same outside diameter as the weld-in plug (maximum tolerance is +0.2 mm)
2. Attach plugs at 4 evenly-spaced points (Fig. 1 below)
3. Screw in weld-in plugs
4. Weld the parts between the 4 points (Fig. 2 below)

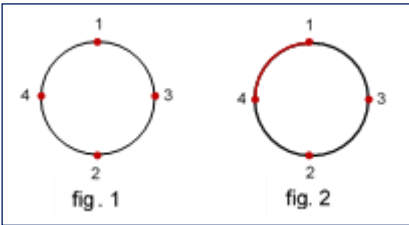
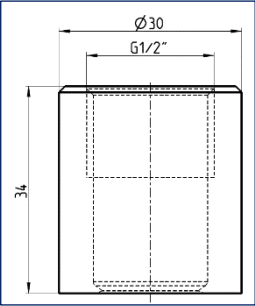

Transmitter

The transmitter is powered by a 24 V DC supply, has a freely programmable contact switch, and a 4...20 mA output for outputting measurement values. The measuring value can be set to 0% via 24V input.

Pressure / Temperature

The EXspect sensor can be used at a pressure up to 10 bar and at a maximum process temperature of 90 °C.

To protect the LED which is used, it is switched off as of a temperature of 90 °C. Measurement is then no longer possible. The display shows the error message "Electricity LED". After lowering the medium temperature below 90 °C, the LED is reactivated and the error message disappears.

NOTE

Please observe the pressure and temperature diagrams in → Chapter 3

Installation locations

In principle, the sensors can be used at any location. However, you must ensure that the pipe is completely filled, and that the sensor is not set up in a place where bubbles form due to agitation of the medium. You should also consider how easy it is to read the display and how easy it is to access and operate the sensor.

The following diagram shows the favoured locations for installing the sensor. As you can see, the sensor is better mounted on the side of the pipe.

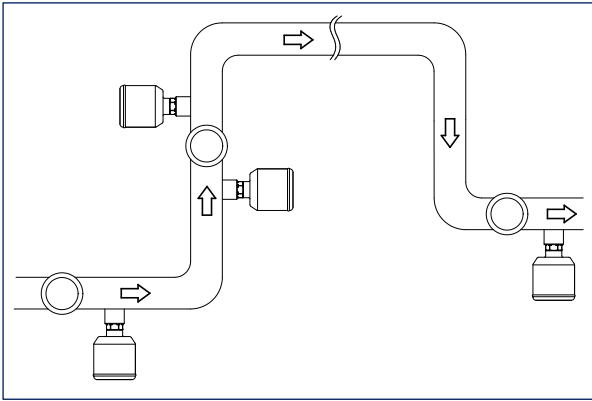

Fig. 6: Installation positions

When installing the sensor, you should ensure that the opening with the measuring windows is in flow direction or parallel to it. If the sensor is assembled against the flow direction, this can lead to the medium being agitated in an unwanted way and/or the formation of bubbles, which can lead to distorted measurement values.

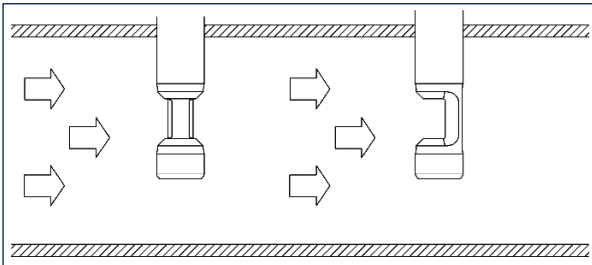

Fig. 7: Sensor positioning

2.4 Checking and adjustment

Reference filters (EXcap 110) with various absorption values are available for inspecting and calibrating the EXspect 231 sensor. If necessary, they can be attached to the sensor. To guarantee the inspection/adjustment is carried out without any errors, you should ensure that the reference filter is placed precisely on the sensor, and that the filter plate is

on the same side of the sensor as the detector. The optical sensor unit must be dry and clean for this.



Fig. 8: Reference filter

In order to be able to carry out an inspection or adjustment of the sensor using the reference filter, the unit "AU" must be selected in advance for the sensor versions "B" and "C". The following table can be used for a comparison of version "A".

AU	0.35	1	2	3
% absorption	55.35	90	99	99

3 EXspect 231 order structure

	Code	Measurement range				
	A	0 - 100% absorption				
	B	0 - 3.5 AU / 0 - 3850 EBC / 0 - 7 OD				
	C	0 - 6 AU / 0 - 6600 EBC / 0...12 OD				
		Code	Optical path length			
		05	5 mm			
		10	10 mm			
		20	20 mm			
		XX	Special version			
		Code	Material (touching medium)			
		4435	Stainless steel 1.4435 / 316 L			
		XXXX	Special version			
		Code	Seal material (touching medium)			
		MET	Metal sealing			
		XXX	Special version			
		Code	Process connection			
		G12	G 1/2"			
		XXX	Special version			
		Code	Interface			
		AS	analogue 4 - 20 mA / 5-pin M12			
		AD	analogue 4 - 20 mA / can be set digitally / 8-pin M12			
		XX	Special version			
			Code	Display		
			1	With integrated display		
			X	Special version		
EXspect 231						Order code

4 Spare parts and accessories

The sensor serial number must always be quoted for spare parts and accessories orders.

Accessories	Order number
2 m EXspect connector cable (M12 5-pin)	2-125-00-001
5 m EXspect connector cable (M12 5-pin)	2-125-00-002
2 m EXspect connector cable (M12 8-pin)	2-120-68-001
5 m EXspect connector cable (M12 8-pin)	2-120-68-002
PC software EXpert 2.x on a USB stick (for Windows)	2-120-69-003
Communication interface ECI-01 EXspect 271/231 for connecting to a PC via USB (connector cable M12 8-pin)	2-120-66-001

4.1 Certificates

Certificates	Order number
Certificate EN10204-2.2 for surface finish ($R_a < 0.37 \mu\text{m}$)	2-121-01-001
Certificate EN10204-3.1 for material	2-121-01-002

4.2 Factory inspection

Factory inspection	Order number
Factory recalibration for NIR sensors incl. certificate (proof of return)	2-999-00-013

4.3 Spare parts

Spare parts	Order number
Operating and display unit	2-118-00-001
Housing cover with inspection glass	2-151-32-001

4.4 Installation adapters

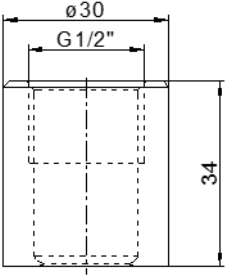
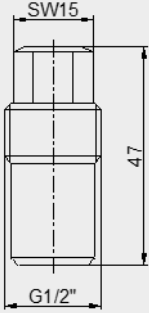
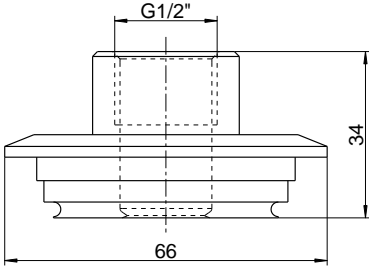
Description	Drawing	Order number
Welding socket G 1/2" cylindrical		2-087-33-003
Brass welding aid G 1/2"		2-086-11-001
Varivent F DN 25-40 process adapter		2-083-33-001

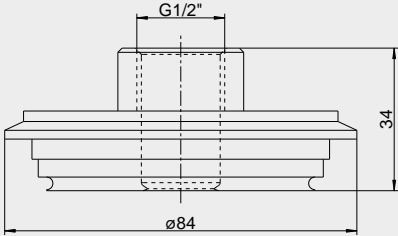
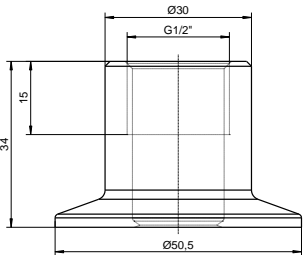
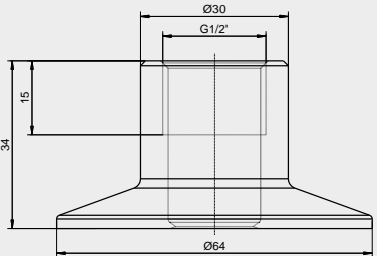
Varivent N DN 40-125 process adapter		2-083-33-002
Process adapter Tri-clamp 1 1/2"		2-083-33-005
Process adapter Tri-clamp 2"		2-083-33-006

4.5 Weld-in pipe with adapter G 1/2"

Material of pipe: 1.4435

Adapter material: 1.4404

Pressure range: 0...10 bar

4 Spare parts and accessories

ØD	L	H	Order number
DN 25	100 mm	51.5 mm	2-083-33-007
DN 32	110 mm	54.0 mm	2-083-33-008
DN 40	120 mm	57.0 mm	2-083-33-009
DN 50	140 mm	63.5 mm	2-083-33-010
DN 60	160 mm	73.5 mm	2-083-33-011

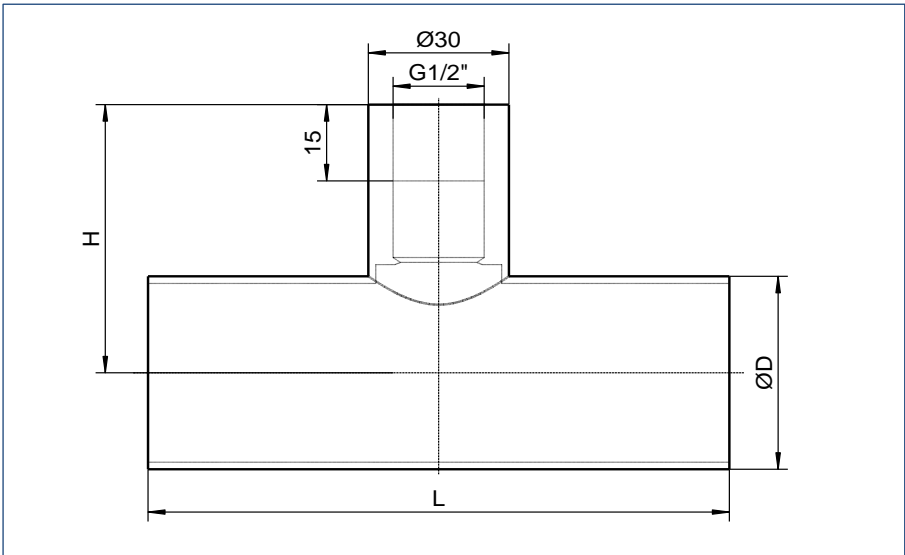

5 Certificates and compliances

Declaration of conformity

for
Turbidity sensor EXspect231

We declare under our sole responsibility that the product, to which this declaration relates is in conformity with the following standards and the normative documents:

EU- Directive	harmonized standards
EMV-Directive 2014/30/EU	DIN EN 61326-1:2013
Modul A	DIN EN 61326-2-3:2013

This declaration applies to all identical specimens of the product, which are manufactured according to the development-, design- and manufacturing drawings and descriptions, which are part of this declaration.

This declaration is given by the manufacturer.

Name of company: **Exner Process Equipment GmbH**
 Address: Carl-Metz-Straße 26
 D-76275 Ettlingen
 Germany



 Place



 Date



 Dettler Exner
 General Manager

EXNER
 Process Equipment GmbH
 Carl-Metz-Straße 26
 76275 Ettlingen • Germany
 fon 07243-945429-0 fax-99
 www.s-p-e.de

7 'o 'Contact:



www.southforkinstruments.com

Tel: 925 461 5059



Exner Process Equipment GmbH
Carl-Metz-Str. 26
D-76275 Ettlingen
Germany

tel +49 (0)7243-94 54 29-0
fax +49 (0)7243-94 54 29-99
mail info@e-p-e.de

www.e-p-e.com