



## RHE21

### Exd / Exd(e) Extreme Environment Multifunction Coriolis Flow Transmitter

#### Features

- Wall or Pipe Bracket Mounting
- Corrosion resistant housing in SS316 available
- Selectable Units for Mass, Volume, Density and Temperature
- Positive, negative and net totalizers for both volume and mass flow
- Two configurable pulse/frequency outputs – double pulse available
- Two analog outputs
- Two configurable digital status outputs
- Outputs are also available as intrinsically safe version
- Configurable digital input
- Analog input configurable for pressure or density
- Advanced functions: Net Oil, Baume/Brix, % Solids, Standard Density and Standard Volume (API MPMS Ch. 11)
- Modbus RTU and HART
- Custody transfer lockout switch and seal point
- Back Lit Color LCD display and 3 behind-glass buttons with intuitive menu design
- USB connection for PC running Rheonik **RHECom** software

- Built-in **Assurance View**® Advanced Diagnostic Set – clear publication of measurement status with **Assurance Factor**® and/or color changing display
- Password Protected Setup
- Upload and download of configuration files
- Power consumption less than 5 W

#### Applications

- General and critical process flows
- Feed stocks and transfers
- Custody transfer
- Well head production
- Offshore

#### Benefits

- More insight into process and measurement conditions with **Assurance View**®
- **Assurance Factor**® for proactive maintenance
- Works with all sizes of Rheonik RHM flow sensors
- Non-corrosive enclosure for extreme environments
- Fast and easy setup using **RHECom** software

## RHE21 General Specifications

<b>Housing:</b>	Stainless steel. Optionally all 316 stainless steel
<b>Enclosure Rating:</b>	IP66 / NEMA 7X. Optionally IP67
<b>Ambient Temperature:</b>	-40 to +60°C / -40 to +140°F (reduced visibility below -20°C / -4°F)
<b>Dimensions:</b>	Depending upon construction type, please see Dimensions page (approx. 255 x 200 x 100 mm / 10 x 8 x 4 in)
<b>Display:</b>	Backlit color LCD. Screen changes color to indicate warning or error
<b>Weight:</b>	8 kg (17.5 lb)
<b>Operation:</b>	3 x behind-window capacitive sensors for menu navigation / settings
<b>Sensor Connection:</b>	Integral sensor cable with 3m or 10m length or optional IS terminal box for separate custom length sensor cable connection
<b>Analog Outputs:</b>	Up to 2 x 4-20mA outputs, active or passive, compl. to NAMUR NE-43 Intrinsically safe versions available Uncertainty of the analog output +/- 0.1% of reading, +/- 10µA
<b>Digital Outputs:</b>	Up to 2 x configurable status outputs (IEC60946) Intrinsically safe versions available
<b>Pulse/Frequency Outputs:</b>	Up to 2 x configurable pulse/frequ. outputs (IEC60946), max 10 kHz
<b>Digital Inputs:</b>	Up to 2 x configurable control inputs (IEC60946)
<b>Analog Input (optional):</b>	1 x 4 - 20 mA analog input (active) for two-wire external sensor
<b>Power Supply:</b>	100-240 VAC (48 to 62 Hz), 5W or 12-24 VDC +/- 10%, 4W
<b>Digital Data Communications:</b>	Modbus RTU (RS485) Connection to a PC (USB) with Rheonik RHECom software HART over analog output
<b>Cable Entries for Power and I/O:</b>	Type E* two M16 x 1.5 entries with Ex e glands 4-11mm (standard) Type E3, E4, E5, EP optional ½" NPT, ¾" NPT, M20 x 1.5, M25 x 1.5 Type H* two ½" NPT
<b>Hazardous Area Approvals:</b>	For ATEX / IEC Ex and cCSAus please see Part Number Code page Others available on request

## Hazardous Area Installation Overview

Zone 0



Zone 1 / Class I, Div. 1



Zone 2 / Class I, Div. 2



Sensor and transmitter must have matching approvals

## Program Packages and Features

### Standard Package (Part Number Code SO)

The RHE2X Standard programming package provides the following measurement and function features:

#### **Direct Mass Flow Measurement**

Mass flow is calculated using the Coriolis principle to provide a high accuracy Mass Flow measurement of the fluid flowing through an Omega Tube Coriolis meter.

#### **Temperature Measurement**

Each Omega Tube Coriolis Sensor provides a temperature measurement from built in sensors.

#### **Fixed Density Function**

The Fixed Density function allows density to be generated based upon process temperature. A base/reference density at a known temperature is entered for the fluid being measured along with a coefficient describing the change in density per temperature unit. The firmware in the transmitter calculates flowing density based upon this information to use for volumetric flow calculations.

#### **Calculated Actual Volume Measurement for Liquids and Gas**

Volume measurement is calculated by dividing direct mass flow measurement by the Fixed Density.

#### **Standardized/Normalized Volume Measurement for Gas**

This function calculates the volume of gas passing through the meter at standard conditions. The density of the gas at standard conditions is entered into the transmitter and the volume is calculated using this in conjunction with the flowing mass.

#### **Password Protection**

All setup and calibration parameters within the meter are protected with passwords to prevent unintentional or unauthorized change once installed.

#### **Batch Controller**

The transmitter is equipped with an onboard batch controller that, in conjunction with external pumps and/or valves allows the precise delivery of a preset mass or volume of process fluid on demand. Operated from the instrument front panel or remotely via operator switches, the controller is configured to utilize either a one stage or a two stage delivery strategy in ensuring the right amount of fluid is batched through the meter. The electronics self-learns, adjusting shut off times as more and more batches are delivered to further refine the amount of delivery, saving material costs and improving quality.

## Program Packages and Features

### Multifunction Package (Part Number Code DO)

The RHE2X Multifunction programming package includes all features from the Standard programming package plus the following measurement and function features:

#### Direct Density and Volume Measurement

The flowing density of the fluid in an Omega Tube Coriolis Sensor is determined from the measured resonant frequency of the sensor and used to calculate instantaneous volumetric flowrate.

#### Brix/Baume Units

The unit can be configured to read out in °Brix or Baume. °Brix or Baume are used extensively in the sugar and beverage industries.

### Multifunction Package with Assurance Diagnostics Suite (Part Number Code AF)

The RHE4x Multifunction Package with Assurance Diagnostics Suite includes everything from the Multifunction package plus the following advanced diagnostic functions:

#### Assurance View® Diagnostics

Inbuilt self-monitoring functions are available that can be used to determine the reliability of the flow meter readings at all times. Diagnostics are quickly accessed through dedicated menu displays, RHECom software and the MODBUS interface.

#### Assurance Factor®

**Assurance Factor®** is a numeric value generated by an internal algorithm that indicates the overall health of the flow meter and measurement. **Assurance Factor®** value can be used to trigger changes in screen color when the optional display is fitted to the RHE45 (White – Amber – Blue – Red), providing highly visible wide area condition indication.

ASSURANCE FACTOR®			
<p><b>WHITE</b></p> <p>Normal Operation <i>No faults present. All parameters within expected limits. Meter fully operational</i></p>	<p><b>AMBER</b></p> <p>Operation Not Optimal <i>Sensor subject to noise / changing conditions in pipe. Measurement quality may be compromised</i></p>	<p><b>BLUE</b></p> <p>Operation at Limit <i>Sensor experiencing disturbance. Measurement quality compromised</i></p>	<p><b>RED</b></p> <p>Measurement Failure <i>Sensor experiencing extreme disturbance / meter in fault. Measurement offline</i></p>

## Program Packages and Features

### Advanced Package (Part Number Code GV)

In addition to all Multifunction functions and the complete Assurance Diagnostics suite, the RHE2X Advanced package includes the following functions:

#### **Standard Volume Calculations to API Standards for Liquid**

This function calculates the volume of fluid passing through the meter at prescribed standard conditions according to API MPMS Chapter 11.

#### **%Solids Measurement**

The transmitter can be configured to generate a %Solids measurement based upon density. Standard flow and density functions are still available while %solids measurement is implemented.

#### **Net Oil Function**

The Net Oil Function Set provides full-stream real-time measurements of water cut, net oil volume flow and net water volume flow. Depending upon meter size, the flow meter can measure well production at rates from a few barrels per day to over 200,000 barrels per day. The net oil calculations are based upon Chapter 11 of the *American Petroleum Institute (API) Manual of Petroleum Measurement Standards*.

### Power Supply Options

The RHE21 can be configured with one of three power supply options:

- **Universal AC Power - 100-240 VAC  $\pm$ 10% (48 to 62 Hz) (Part Number Code A1)**
- **Wide Tolerance DC Power - 12-24 VDC  $\pm$ 10%, 4W (Part Number Code D1)**
- **Dual Supply - 100-240 VAC  $\pm$ 10% (48 to 62 Hz) / 12-24 VDC  $\pm$ 10%, 4W (Part Number Code U1)**  
This unique option provides inputs for simultaneous connection of both a universal AC and separate DC supply. The transmitter utilizes AC power when available but will switch to the DC supply in the event of AC power outage. The DC supply can be a battery source. As an example, an RHE27 transmitter and connected sensor will operate for 10 days or more on a typical automobile battery.



## RHECom Software

The RHE2X transmitters are fully featured devices with many sophisticated functions and configuration is necessary for proper performance of these functions. **RHECom** software is available in three versions – **Free**, **Pro** and **Pro+**.

**RHEComFree** is available for download at **no extra cost** or on USB flash drive. **RHEComFree** allows full setup of transmitter parameters and includes a useful datalogging function for monitoring performance of the meter.

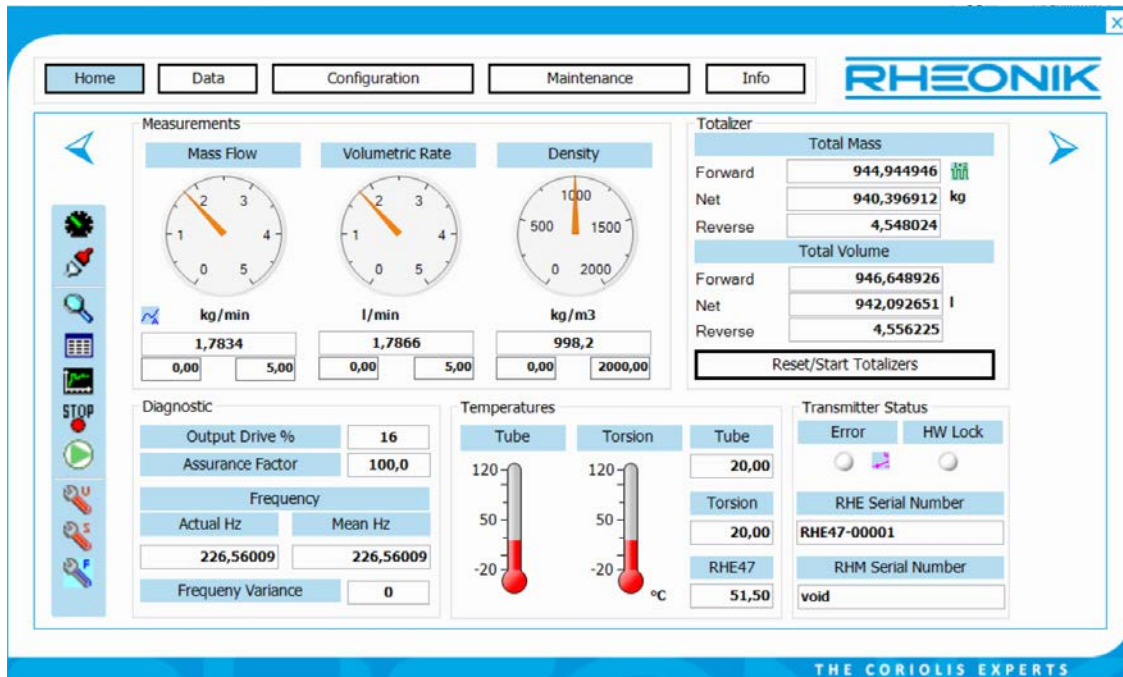

For a one-time license fee, **RHEComPro** and **RHEComPro+** offer additional insight and setup convenience menus. **RHEComPro** includes data logging, trending and broad diagnostic capabilities.

**RHEComPro+** takes flow meter management one step further with a **revolutionary fully functioning simulator application**. With the simulator, you can trial run your application from the convenience of your office, adjusting transmitter settings, setting alarms and filters, and creating transmitter configuration files for upload into the actual unit. The simulator is also ideal for training - it exactly mimics the front panel of the instrument display and buttons when clicked and includes controls for adjusting flow, density and temperature readings just like the unit was in line!

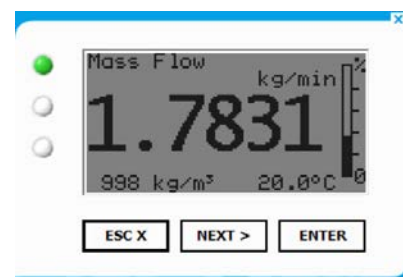
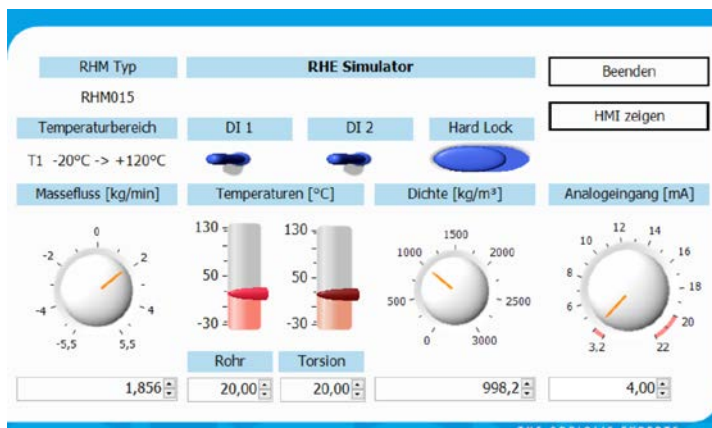

RHECom software is designed to ensure simple and expedient setup of Rheonik transmitter features and functions – a real time saver and a valuable tool.

## RHE21 Dimensions Type E1, E2

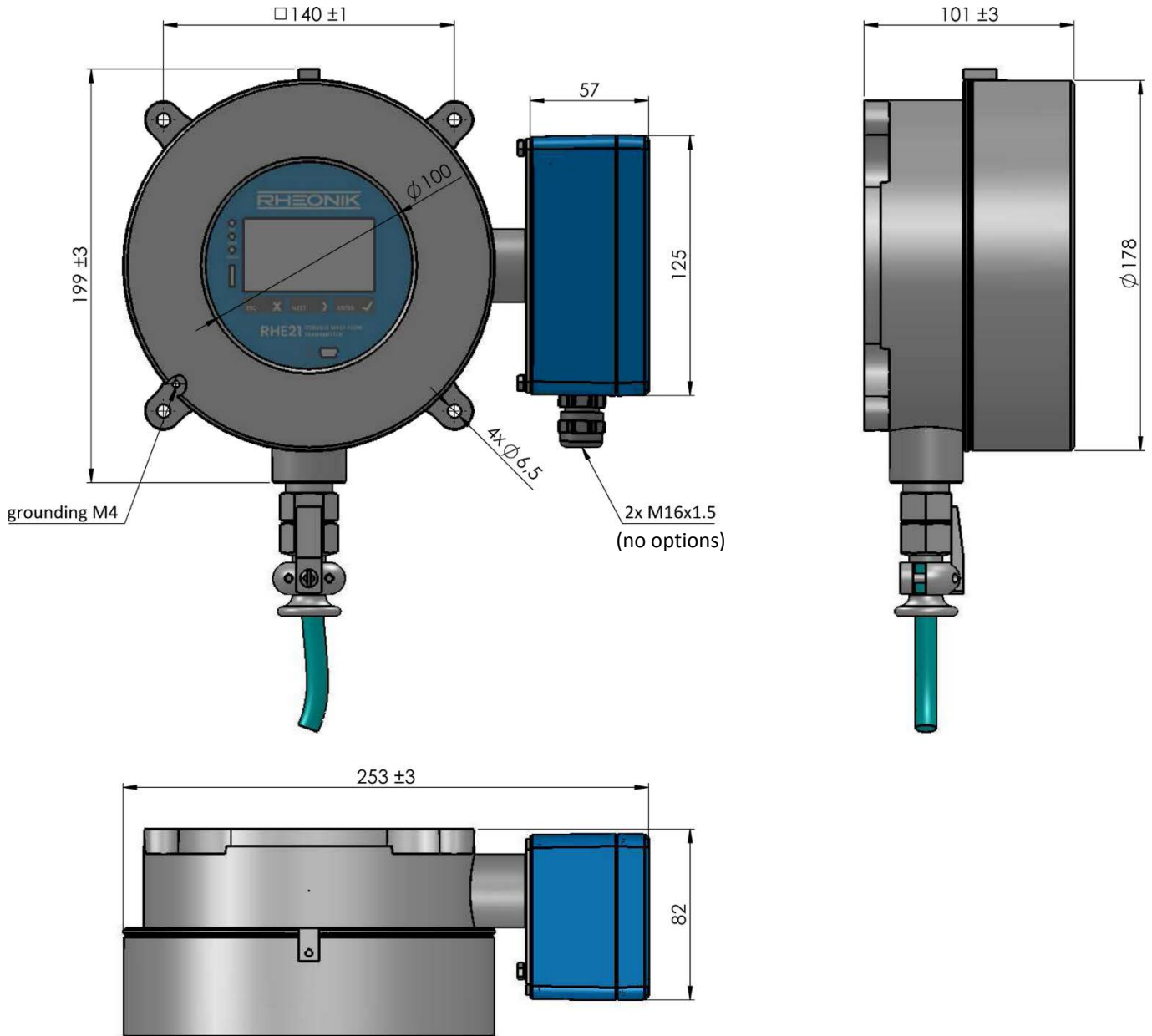

All dimensions in mm

## RHE21 Dimensions Type E3, E4

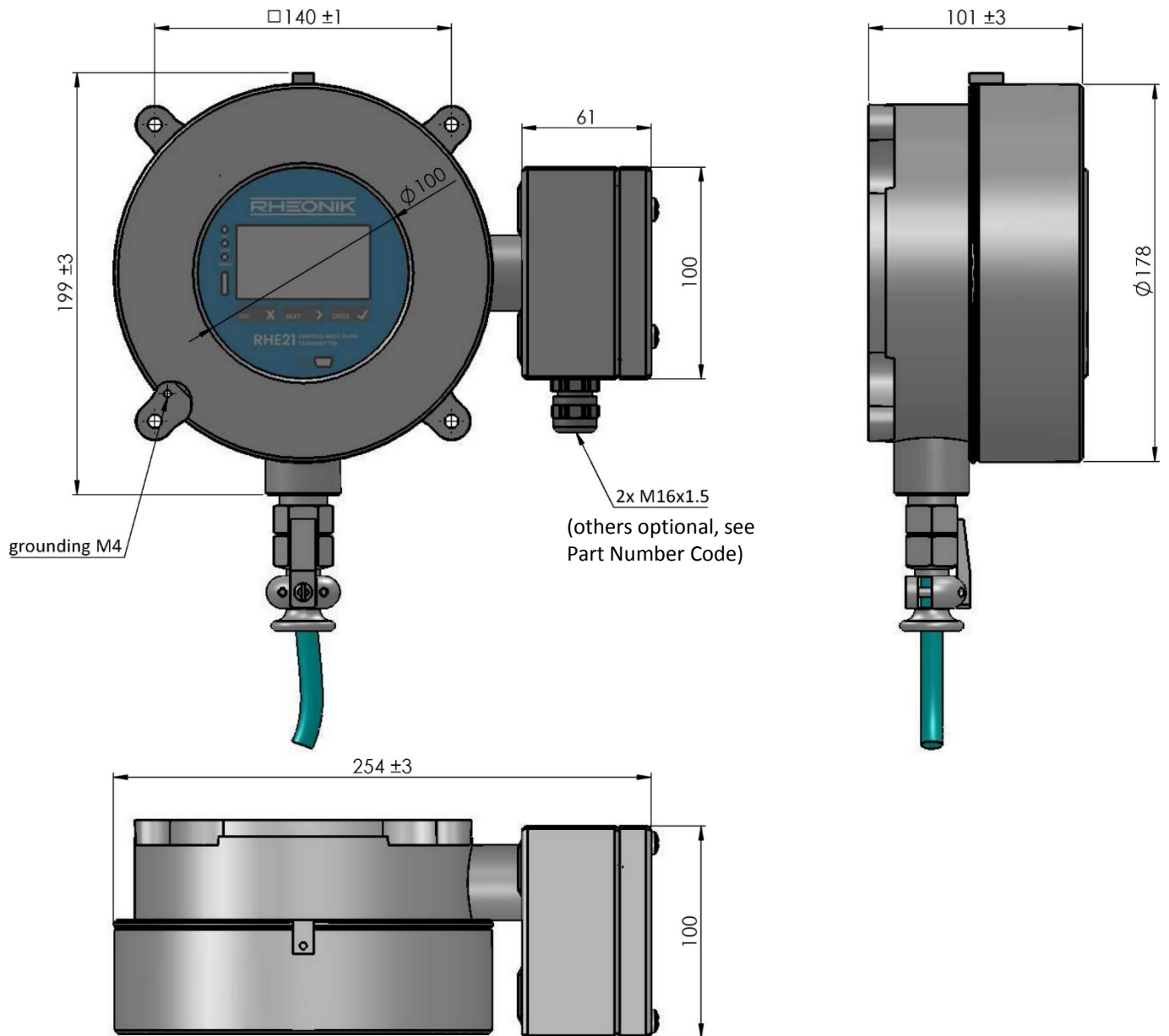

All dimensions in mm



## RHE21 Dimensions Type EP

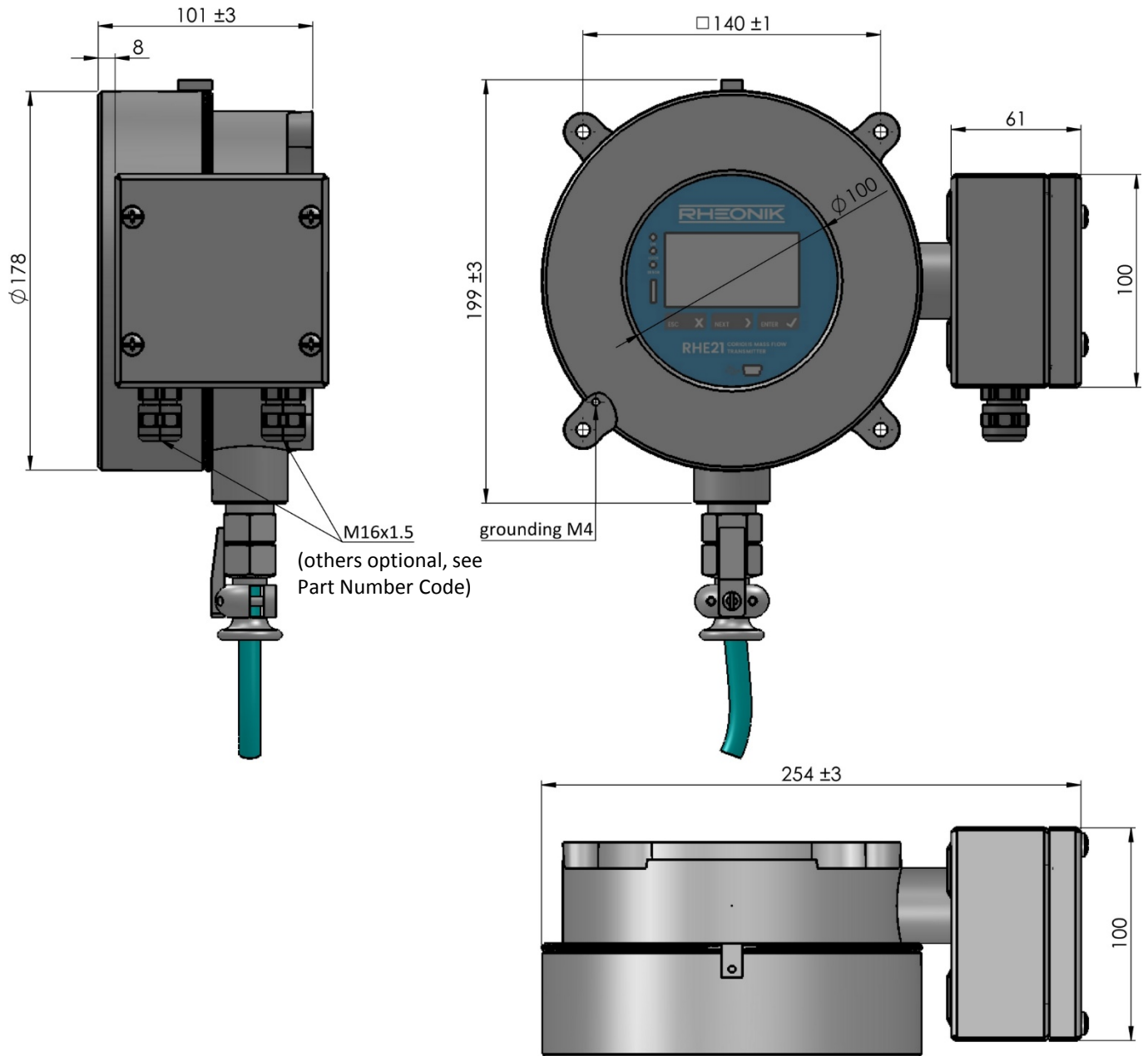

All dimensions in mm

Type EP for panel mount: 8 mm recessed I/O terminal box to fit RHE21 display front into panel window

## RHE21 Dimensions Type E5

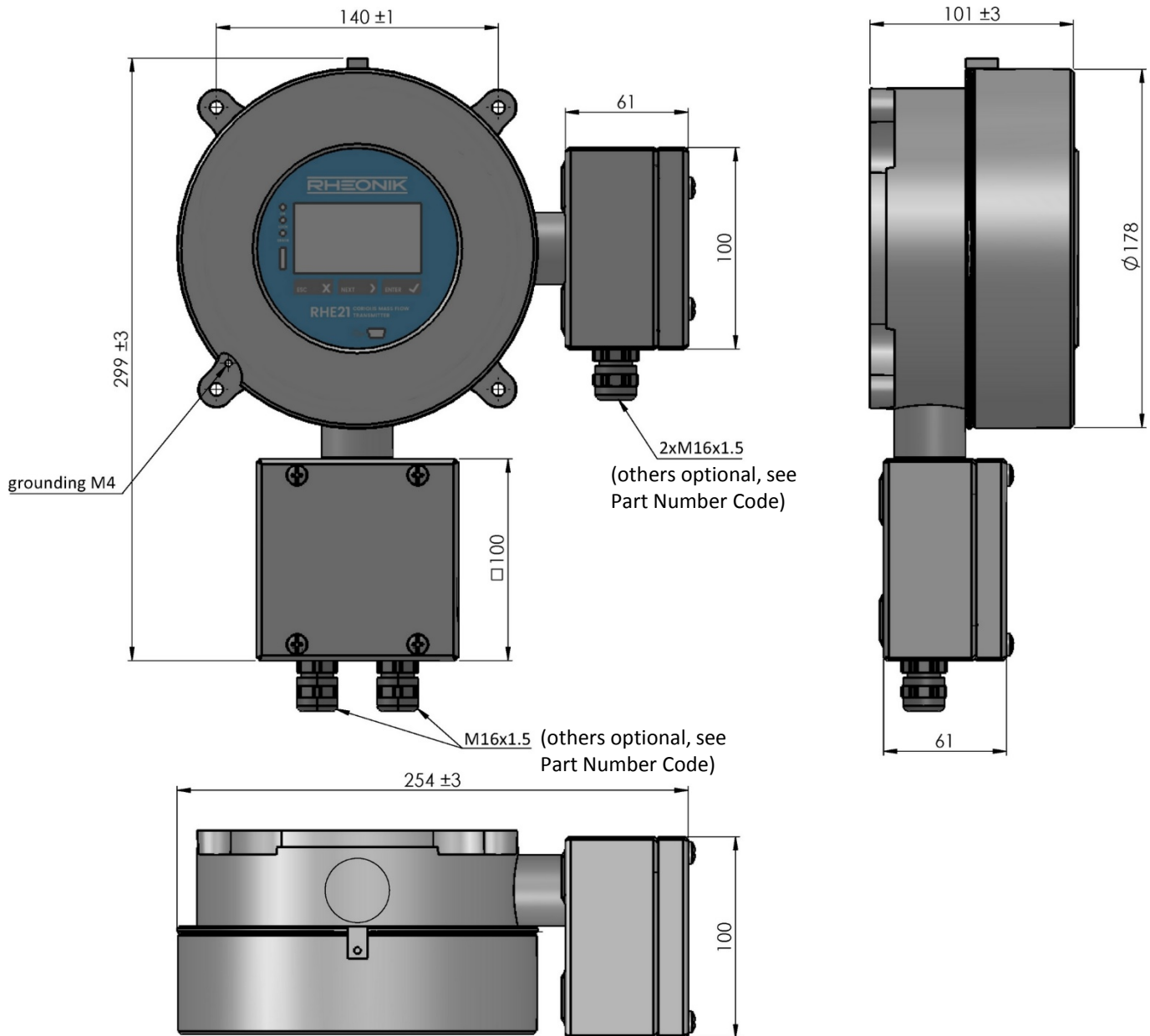

All dimensions in mm

## RHE21 Dimensions Type H1, H2

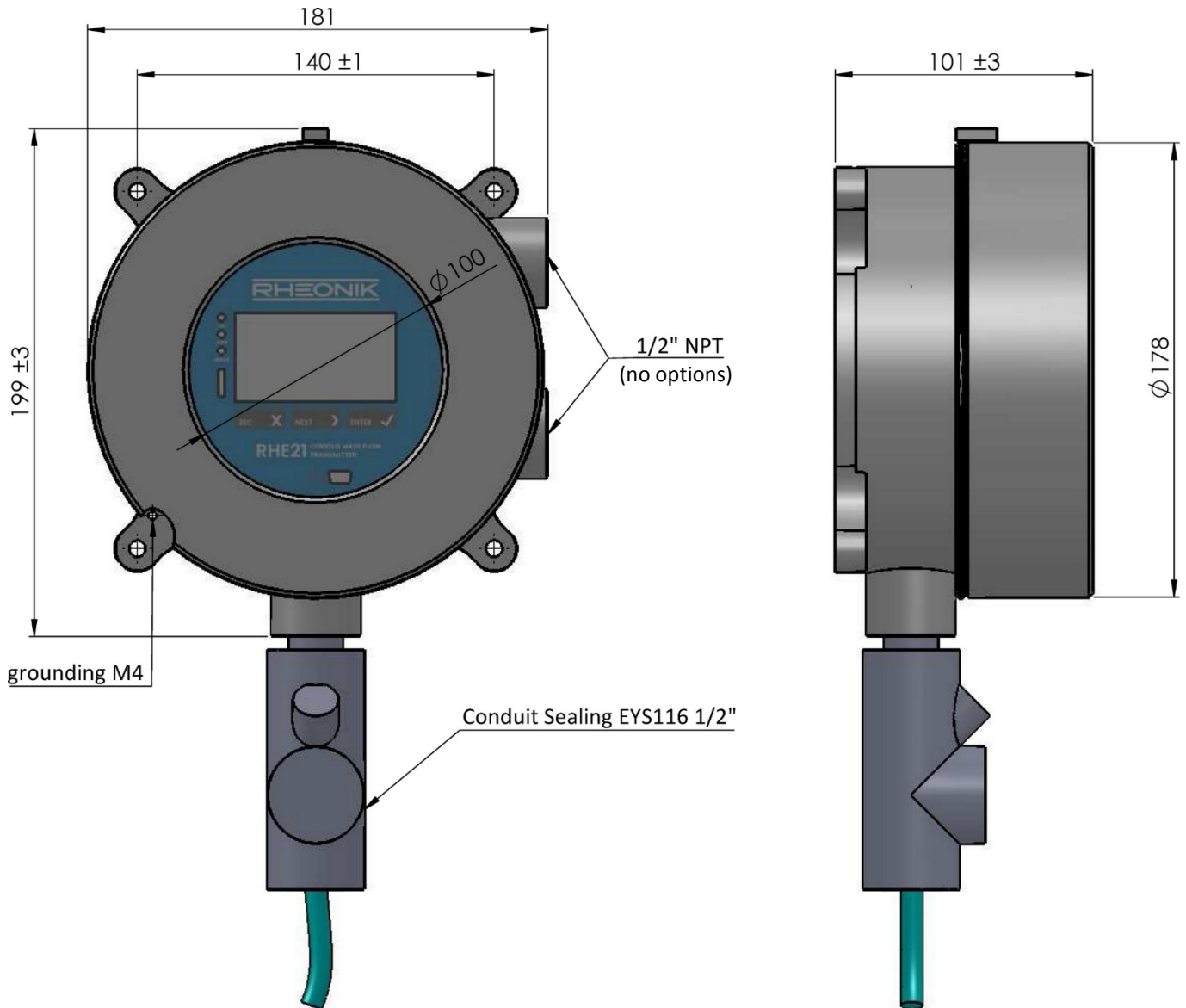

All dimensions in mm

Drawing shows CSA version. ATEX/IECEx version has the same RHM connection part as Type E1, E2, E3, E4

## RHE21 Dimensions Type H3

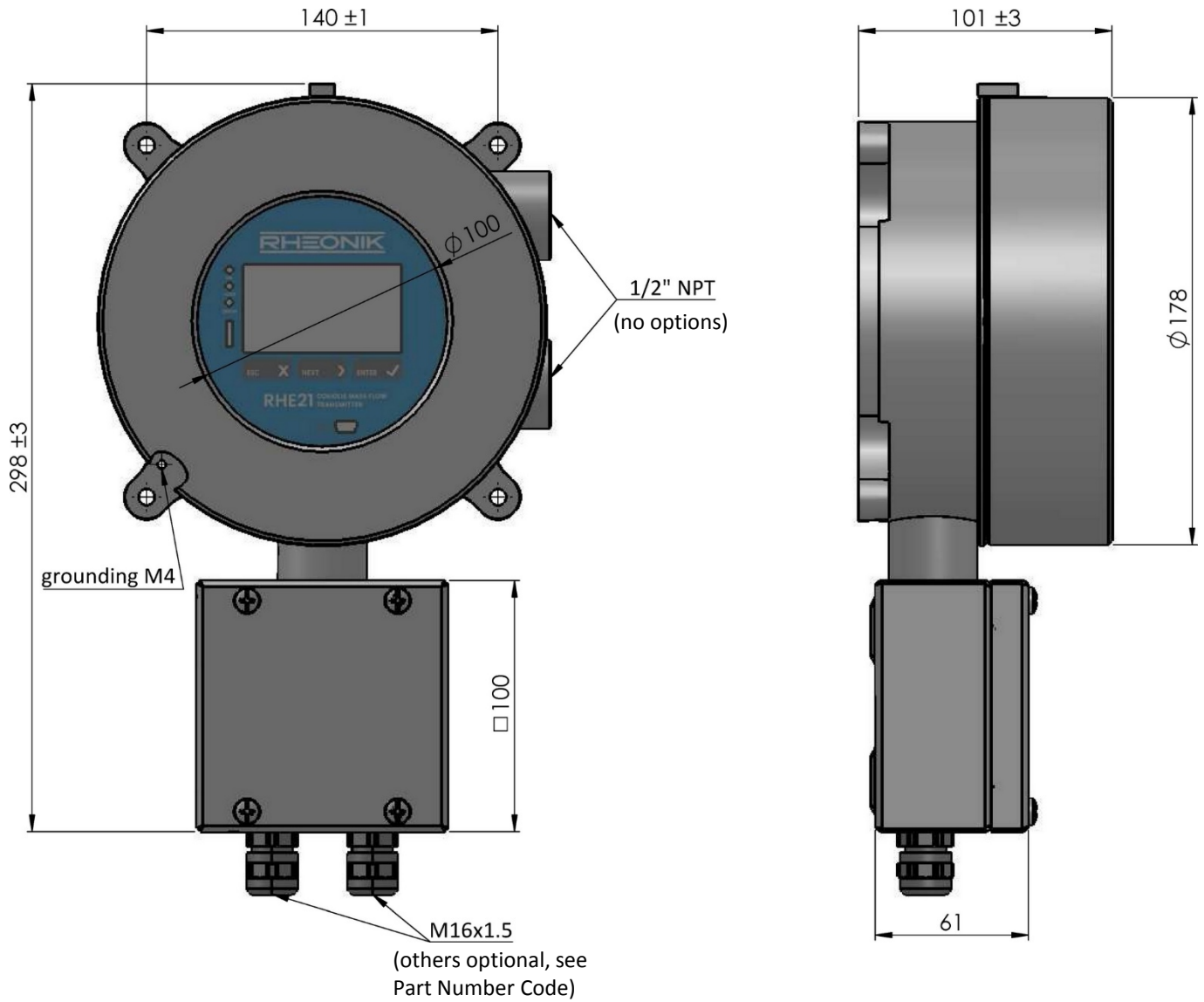

All dimensions in mm

## RHE21 Part Number Code

### Construction Type

- E1** Stainless steel enclosure Exd(e) with 3m integral sensor cable and Alu. TB for power & I/O
- E2** Stainless steel enclosure Exd(e) with 10m integral sensor cable and Alu. TB for power & I/O
- E3** SS316 enclosure Exd(e) with 3m integral sensor cable and SS316 TB for power & I/O
- E4** SS316 enclosure Exd(e) with 10m integral sensor cable and SS316 TB for power & I/O
- EP** SS316 enclosure Exd(e) for panel mount with 10m integral sensor cable and SS316 TB for power & I/O
- E5** SS316 enclosure Exd(e) with two SS316 terminal boxes for sensor cable and power & I/O
- H1** Stainless steel enclosure Exd with 3m integral sensor cable and two cable entries for power & I/O
- H2** Stainless steel enclosure Exd with 10m integral sensor cable and two cable entries for power & I/O
- H3** SS316 enclosure Exd with SS316 terminal box for sensor cable and two cable entries for power & I/O

### Supply Voltage

- D1** 12 to 24 VDC (+/- 10%)
- A1** 100 to 240 VAC (48 to 62 Hz)
- U1** 12 to 24 VDC (+/- 10%) and/or 100 to 240 VAC (48 to 62 Hz) - only Type H\*

### Software Function Pack

- SO** Standard package: mass flow with normalized density / volume
- DO** Multifunction package: mass flow with measured density / volume
- AF** Multifunction package - as DO plus Assurance Factor® diagnostics suite
- GV** Multifunction package - as AF plus API standard volume / net oil / concentration
- CT** Multifunction package - as GV plus hardware lock switch function

### I/O Configuration

- S1** Standard One - 1\*4/20mA (active), 2\*DO (Pulse/Freq/Status), 1\*DI, RS485 (Modbus)
  - S2** Standard Two - 2\*4/20mA (active), 1\*DO (Pulse/Freq/Status), 1\*DI, RS485 (Modbus)
  - P1** Standard One - 1\*4/20mA (passive), 2\*DO (Pulse/Freq/Status), 1\*DI, RS485 (Modbus)
  - P2** Standard Two - 2\*4/20mA (passive), 1\*DO (Pulse/Freq/Status), 1\*DI, RS485 (Modbus)
  - SH** HART - as S2 plus HART
  - PH** HART - as P2 plus HART
  - CH** Premium - as PH plus analog input. Only with type E5, H3
- Intrinsically Safe Outputs (only with Type E\* and 24VDC supply D1)**
- i1** One - 1\*4/20mA (passive, is), 2\*DO (Pulse/Freq/Status, is), RS485 (Modbus, non-is)
  - i2** Two - 2\*4/20mA (passive, is), 1\*DO (Pulse/Freq/Status, is), RS485 (Modbus, non-is)
  - i3** HART - as One i1 plus HART
  - iH** HART - as Two i2 plus HART

### Hazardous Area Approval

- NN** Without - RHM and RHE in ordinary locations
- AS** ATEX/IEC <Ex> (1)G [Ex ia Ga] IIC - RHM in all zones, RHE in ordinary locations
- A2** ATEX/IEC <Ex> II 3(1)G Ex db [ia Ga] IIC T4 Gc - RHM in all zones, RHE in zone 2
- A1** ATEX/IEC <Ex> II 2(1)G Ex db [ia Ga] IIC T4 Gb - RHM in all zones, RHE in zone 1
- CS** cCSAus Class I, associated equipment - RHM in all divisions, RHE in ordinary loc. (only Type H\*D1)
- C2** cCSAus Class I, Div. 2, Groups A,B,C,D - RHM in all divisions, RHE in division 2 (only Type H\*D1)
- C1** cCSAus Class I, Div. 1, Groups A,B,C,D - RHM and RHE in all divisions (only Type H\*D1)

RHE21

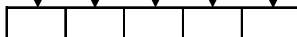

### Options for RHE 21

<b>N67</b>	Upgrade to IP67 rating
<b>H-316</b>	Set of two brackets for hook mounting in SS316
<b>E1</b>	1/2" NPT cable entries instead of M16 Ex e glands
<b>E2</b>	M20 x 1.5 cable entries instead of M16 Ex e glands
<b>E3</b>	3/4" NPT cable entries instead of M16 Ex e glands
<b>E4</b>	M25 x 1.5 cable entries instead of M16 Ex e glands
<b>MO</b>	Modbus RS485 (screw terminals) to PC USB converter - to operate RHECom

## Flow Sensor Range



*Some of the many RHM mass flow sensors available*

The RHM range of mass flow sensors features:

<b>Line Sizes</b>	From DN1 to DN300 / 1/24" to 12"
<b>Pressure Ratings</b>	Up to 1379 bar / 20000 psi
<b>Temperature Ratings</b>	From -200°C to 400°C / -328°C to 752°F
<b>Wetted materials</b>	Stainless Steel, Alloy C22, Duplex, Super Duplex, Tantalum, Others

RHE21 transmitters can be connected to all RHM Flow Sensors in the Rheonik Omega Tube range. Together they make a high performance measurement package suitable for many applications. For specific details on any sensor size, please see the relevant specification sheet.

## About Rheonik

Rheonik has a single purpose: to design and manufacture the very best Coriolis meters available. Our research and engineering resources are dedicated to finding new and better ways to provide cost effective accurate mass flow solutions. Our manufacturing group care for each and every meter we produce from raw materials all the way to shipping and our service and support group are available to help you specify, integrate, start-up and maintain each and every Rheonik meter you have in service. Whether you own just one meter or have hundreds, you will never be just another customer to us, you are a valued business partner. Need a special configuration for your plant - don't compromise with a "standard" product from elsewhere. If we can't configure it from our extensive product range, we can build you what you need as a custom meter.

Rheonik only make Coriolis meters - we are **The Coriolis Experts** - contact us for all of your Coriolis meter requirements.