



RHM06L

Coriolis Mass Flow Meter for Low Flow Measurement in Process Applications

Features

- Standard pressure ratings up to 1043 bar (15127 psi)
- Temperature ratings from -196 to 350°C (-320 to 662°F)
- Mass flow uncertainty down to 0.10%
- Repeatability better than 0.05%
- Typical measuring ranges between 0.25 and 20 kg/min
- Accurately measure low flow rates down to 150 g/min
- Unique robust torsion driven oscillation system
- Rheonik **AnyPipeFit Commitment** brings you the possibility to get any custom process connection type and size for savings on installation costs. Compact design with minimal footprint
- Approved for use in hazardous areas
- Stainless steel case
- Removable connection manifold version available for easy and efficient maintenance

Applications

- General Flow Control
- Additive Dosing
- Mixing and Batching
- Chemical Injection
- Package and Container Filling

Rheonik Sensor Benefits

- Torsion oscillator design assures a stable and drift free measurement with excellent signal to noise ratios
- Resilient to external noise and vibration
- Insensitive to pipe pressure changes
- Robust tube wall thickness provides increased operational safety in abrasive applications
- Long sensor life guaranteed due to low mechanical stresses in the meter mechanism
- No moving parts to wear or fail

General Specification Overview

Nominal Flow (Q_{nom})*	20 kg/min (44.1 lb/min)
Minimum Flow (Q_{min})*	0.5 kg/min (1.1 lb/min)
Serial Tube/ Single Path	Flow rates Q_{nom} and Q_{min} will be 50% of the above listed parallel/dual tube version
Operating Temperature	Temperature range options cover applications from -196°C to 350°C (-320°F to 662°F)
Pressure Ratings	Up to 1043 bar / 15127 psi - dependent upon material
Electrical Connection	Cable entry M25 x 1.5 (standard), M20 x 1.5, ½" NPT, ¾" NPT (optional) Max. cable length to remote RHE transmitter 100m / 330ft
Sensor Enclosure Materials	Stainless steel (standard), 316 stainless steel (optional) Epoxy coated aluminum terminal box (standard), 316 stainless steel terminal box (optional)
Enclosure Type	Protection class IP65 (standard); IP 66 / NEMA 4X (optional)
Wetted Materials	1.4571 (316Ti), 2.4602 (Alloy C22), Tantalum, 1.4410 (SuperDuplex) Seal material (manifold construction): PTFE Additional/customer specific materials available upon request
Process Connections	Nearly any - the RHEONIK AnyPipeFit Commitment . Consult factory for types/sizes not listed in this data sheet
Pressure Rating Compliance	Europe - PED according to Sound Engineering Practice (SEP)
Certifications and Approvals	ATEX / IECEx Approvals for zone 0, 1, 2 (suitably rated RHE transmitter required) North American Approvals for Class I, Div. 1, Groups ABCD (suitably rated RHE transmitter required) American Bureau of Shipping (ABS) Product Type Approval for use on marine vessels
Documentation, Testing and Inspection	All sensors are hydro tested, calibrated and supplied with a traceable calibration certificate. Customized calibration and testing services available
Project Documentation and QA, Services	Rheonik offers a full set of services for large and complex engineering projects. Typical services offered are, but not limited to: <ul style="list-style-type: none"> • Certificates of origin and conformity, mill certificates • Data books including WPAR, WQS, NDT, test & quality plans, functional testing, calibration procedures, customized packing, factory acceptance etc. • Start up and commissioning services on/offshore
Options	Enclosure heating for high temperature applications Cleaning for oxygen service Full service painting to project specifications – consult factory

* At Q_{nom} pressure drop across a parallel tube sensor will be approximately 2 bar (29 psi) for H₂O. Sensors can be operated at higher flow rates but pressure drop will be higher. Maximum recommended velocity (liquid) through the sensor is 15 m/s. Beyond this point, cavitation may occur. Q_{min} is the recommended lowest flow rate. Sensors will measure flow rates lower than Q_{min} , but uncertainty will increase beyond 0.5% of rate.

The flow rate specifications above relate to P1 pressure parallel tube sensor versions. Models with higher pressure ratings have increased wall thickness and will have higher pressure drops/lower Q_{nom} values.

Measurement Performance

Standard Calibration

A	0.5% Uncertainty ±0.5% uncertainty between Q_{nom} and Q_{min}
B	0.2% Uncertainty ±0.2% uncertainty between Q_{nom} and $Q_{0.2}$

Higher pressure units may have lower Q_{nom} values due to reduced tube ID

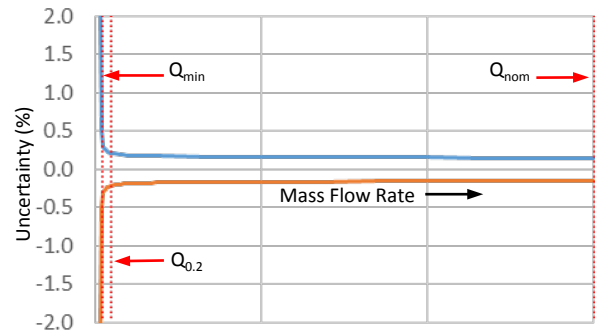

Goldline Calibration

G	0.12% Uncertainty ±0.12% uncertainty between Q_G and $(Q_G/20)$
P	0.1% Uncertainty ±0.1% uncertainty between Q_G and $(Q_G/10)$

Only for sensors with standard temperature and pressure range
Customized calibration services are available – consult factory

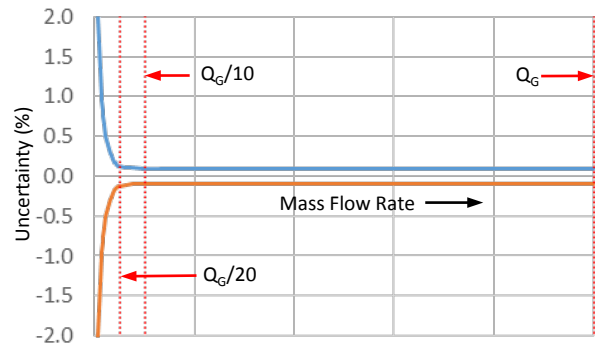

Low Flow Calibration

C	1:20 Turn Up Calibration ±0.2% uncertainty between Q_{min} and $(Q_{min} * 20)$
1	Low Flow Optimized Calibration ±0.2% uncertainty between Q_{min} and $(Q_{min} * 20)$ and ±0.6% uncertainty between Q_{min} and Q_{low}

Only for sensors with standard temperature and pressure range

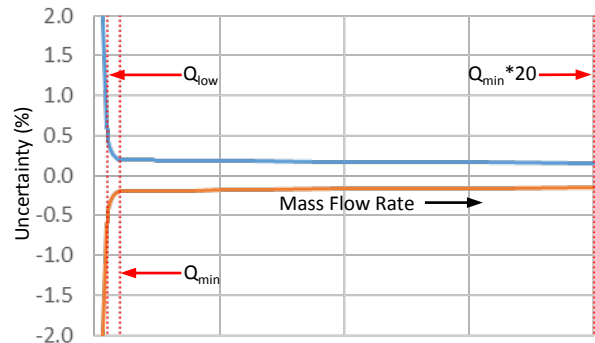

Q_{nom}	20 kg/min (44.1 lb/min)
Q_{min}	0.5 kg/min (1.1 lb/min)
Q_G	20 kg/min (44.1 lb/min)
$Q_{0.2}$	1 kg/min (2.2 lb/min)
Q_{low}	0.3 kg/min (0.7 lb/min)

Select the calibration option (A,B,G,P,C,1) required and include in the overall part number
For Serial Tube versions, the Q values above are halved

Flow Measurement Repeatability

Standard ± 0.1% of rate
Goldline ± 0.05% of rate

Temperature Performance

Better than ±1°C

Density Calibration

N*	No Live Density Calibration
S	Standard +/- 0.01 kg/liter uncertainty between 500 and 1400 kg/m3
D	Enhanced +/- 0.005 kg/liter uncertainty between 500 and 1400 kg/m3

Density performance relates to P1 pressure range. For live volumetric flow, S or D calibration must be included in the part number and the sensor must be operated by an RHE with live density capability.

* Even with No Live Density Calibration, volumetric flow can still be calculated with an inferred density value based upon a manually entered norm density value and its temperature gradient.

Calibration Reference Conditions

Performance statements relate to the following conditions:

- Water (for mass flow accuracy)
- Temperature: 18 to 24°C (66 to 76°F)
- Pressure at 1 to 3 barg (15 to 45 psig)
- RHM with standard temperature, material and pressure range

Measurement Tube Pressure Ratings

The maximum pressure (P_{max}) of a sensor is determined by its lowest rated part. The lowest rated part can be either the measurement tube (P_{max} indicated below), the construction type (P_{max} indicated in the Part Number Code section) or the process connection (for P_{max} see published standards or manufacturer information).

Pressure Code	Material Code	Material	Pmax				
			bar	psi	@	°C	°F
P1 (low pressure drop)	M1	1.4571 (316Ti) UNS S31635	202	2930	@	50	122
			181	2625	@	120	248
			156	2263	@	210	410
			131	1900	@	350	662
P2 (std.)	M1 (std.)	1.4571 (316Ti) UNS S31635	437	6338	@	50	122
			380	5511	@	120	248
			300	4351	@	210	410
			260	3771	@	350	662
	M3*	2.4602 (Alloy C22) UNS N06022	590	8557	@	50	122
			524	7600	@	120	248
			414	6005	@	210	410
			358	5192	@	350	662
	M4**	Tantalum UNS R05200	88	1276	@	50	122
			78	1131	@	120	248
			67	972	@	210	410
			1043	15127	@	50	122
	10***	1.4410 (Super Duplex) UNS S32750	915	13271	@	120	248
			827	11995	@	210	410
			833	12082	@	50	122
	62***	1.4462 (Duplex) UNS S31803	730	10588	@	120	248
639			9268	@	210	410	

* Only with seal-less construction types

**Only with N1, NA, E2 temperature range (note max. operating temp. is 130°C) and PF0 construction type (max. ANSI 600 / PN 100)

***Only with N1, NA, E2 temperature range (note min. temp. is -40°C) and seal-less construction type

Other Materials and Pressure Ratings

Higher pressure rated measurement tubes in the materials above may be possible. Other wetted materials (e.g. Inconel, Monel, 304 stainless steel, others) are also possible for chemical compatibility, lower pressure drop, abrasion allowance and other application specific requirements.

Contact factory with specification for assessment and availability.

Mechanical Construction

Sensors are manufactured with two internal measurement tubes arranged side by side. In parallel or dual path sensors (order code Pxx), these tubes are connected in parallel and the flowing fluid is split equally between them. In serial or single path sensors (order code Sxx), the internal tubes are connected end to end, creating a single path through which all fluid flows. Manifold designs have a removable inlet/outlet manifold block and utilize PTFE seals between the manifold and sensor body. In seal-less designs, the measurement tubes are continuous between the process connections and do not have seals. Manifold designs offer shorter delivery lead times and may have a lower pressure drop than seal-less designs for the same flow rate.

Manifold design with seals - flange connections

PMO: parallel/dual path

SMO: serial/single path

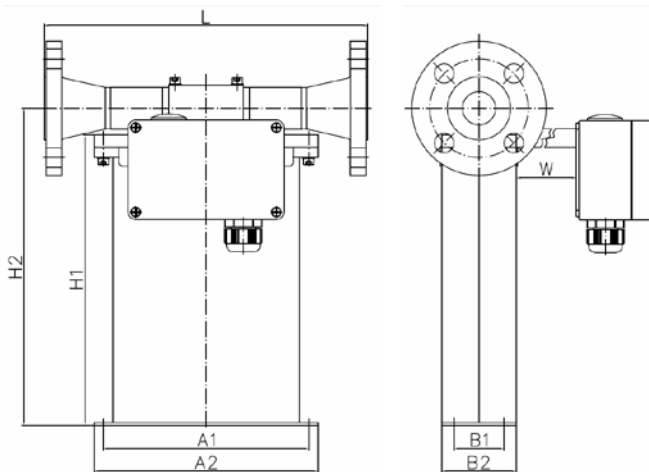

Process Connection	Dim. L	Dim. H2	Order Code
	mm / in	mm / in	
ANSI ½" 150#RF	260 / 10.24	255 / 10.04	A4
ANSI ½" 300#RF	260 / 10.24	255 / 10.04	A5
ANSI 1" 150#RF	260 / 10.24	255 / 10.04	A1
ANSI 1" 300#RF	260 / 10.24	255 / 10.04	A2
ANSI 1" 600#RF	300 / 11.81	255 / 10.04	A3
ANSI 1" 1500#RF	350 / 13.78	255 / 10.04	A6
ANSI 1" 1500#RTJ	350 / 13.78	255 / 10.04	R1
DIN DN25/PN40 Form C	260 / 10.24	255 / 10.04	D1
DIN DN25/PN100 Form E	300 / 11.81	255 / 10.04	D2
DIN DN15/PN40 Form C	260 / 10.24	255 / 10.04	D4
JIS RF10K 15A (½")	260 / 10.24	255 / 10.04	J4
JIS RF20K 15A (½")	260 / 10.24	255 / 10.04	J5

1. Manifold blocks are manufactured from 316Ti (1.4571) stainless steel

Manifold design with seals - threaded connections

PMO: parallel/dual path

SMO: serial/single path

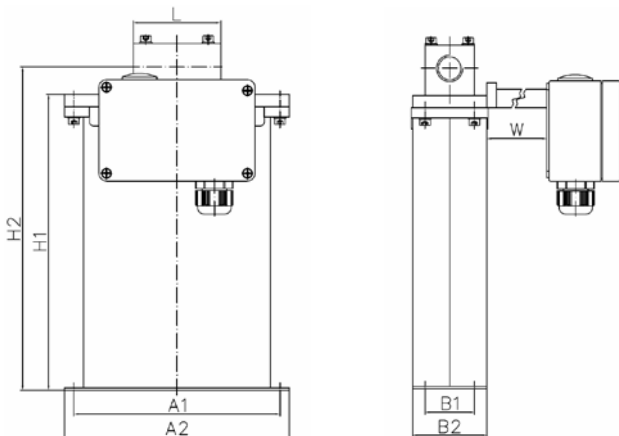

Process Connection	Dim. L	Dim. H2	Order Code
	mm / in	mm / in	
Female Thread G ½"	70 / 2.76	255 / 10.04	G1
Female Thread ½" NPT	70 / 2.76	255 / 10.04	N1

1. Manifold blocks are manufactured from 316Ti (1.4571) stainless steel

Dimensions	mm	in
	A1	165
A2	180	7.09
B1	40	1.57
B2	60	2.36
H1	234	9.21

Standard blue terminal box in Aluminum, size = 125 x 80 x 57 mm (4.92 x 3.15 x 2.24 in)
- optionally available with integral RHE45 transmitter

Optional SS 316 box, size = 100 x 100 x 61 mm (3.94 x 3.94 x 2.40 in)
- only for remote transmitter

W = 0 mm (0 in) for Aluminum box and Temperature Range N1 and NA
W = 30 mm (1.2 in) for SS 316 box and Temperature Range N1 and NA
W = 150 mm (5.91 in) for all other combinations

NOTE: Junction boxes are supplied with M25 x 1.5 cable entries as standard. M20 x 1.5, ½" NPT, ¾" NPT cable entries are optionally available and must be ordered separately.

All dimensions are for standard products. For customization of face to face length and/or process connection types other than the ones listed on this page, please consult factory. Note that larger diameter flange process connections are always possible.

Mechanical Construction (continued)

Seal-less design with flange connections

SFO: serial/single path

PFO: parallel/dual path

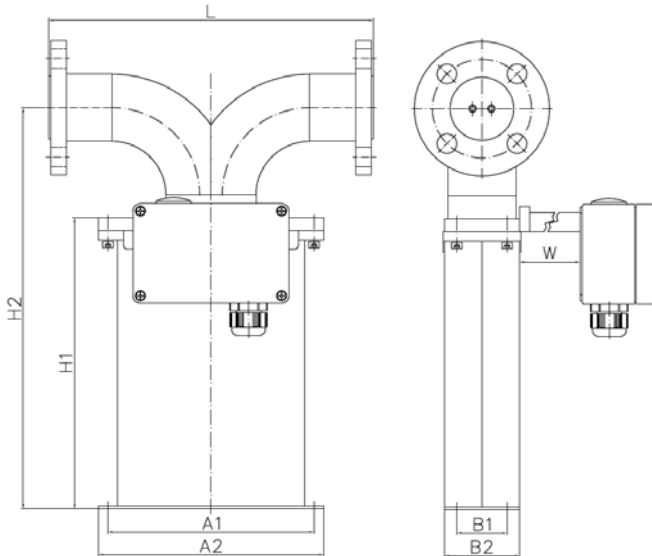

Process Connection	Dim. L	Dim. H2	Order Code
	mm / in	mm / in	
ANSI 1" 150#RF	260 / 10.24	322 / 12.86	A1
ANSI 1" 300#RF	260 / 10.24	322 / 12.86	A2
ANSI 1" 600#RF	300 / 11.81	322 / 12.86	A3
ANSI 1" 1500#RF	300 / 11.81	322 / 12.86	A6
ANSI 1" 2500#RF	300 / 11.81	322 / 12.86	A8
ANSI 1" 1500#RTJ	300 / 11.81	322 / 12.86	R1
ANSI 1" 2500#RTJ	300 / 11.81	322 / 12.86	R2
DIN DN25/PN40 Form C	260 / 10.24	322 / 12.86	D1
DIN DN25/PN100 Form E	300 / 11.81	322 / 12.86	D2
Sanitary ½" Triclamp, DIN 32676 (only with SFO)	230 / 9.06	255 / 10.04	S1

1. For hub connectors (e.g. Destec, Galperti, Grayloc, Techlok) or JIS flanges please consult factory
2. SFO meters contain brazed joints with process contact. Brazing material is B-Ni82CrSiBFe-970/1000
3. Pmax for sanitary fittings is 40 bar (580 psi) @ 120°C (248°F).
4. Meter will be supplied with a 1.4571 (316Ti) stainless steel backing flange and wetted material facing disc for some material selections (e.g. Tantalum)
5. Other dimensions on previous page

Seal-less design with threaded or tube connections

PFT: parallel/dual path

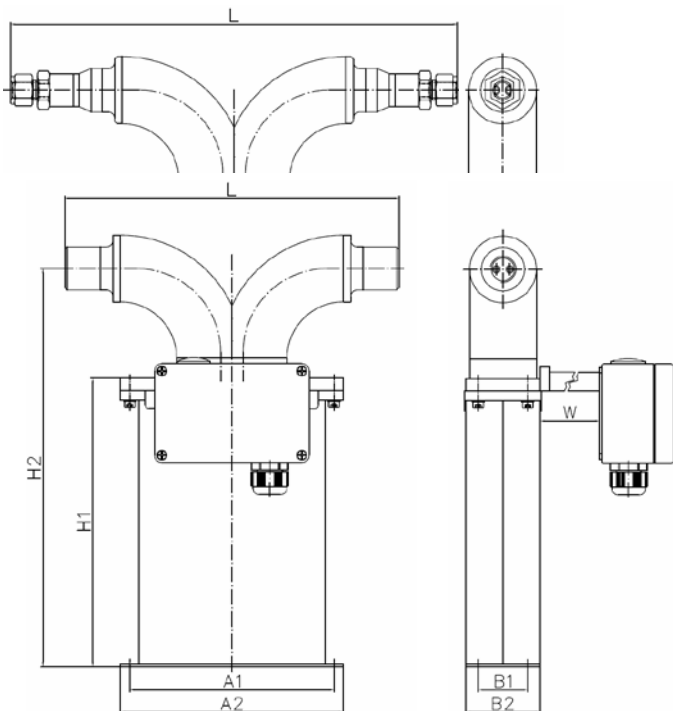

Process Connection	Dim. L	Dim. H2	Order Code
	mm / in	mm / in	
Female Thread G ½"	270 / 10.63	322 / 12.86	G1
Female Thread ½" NPT	270 / 10.63	322 / 12.86	N1
Swagelok ½" Tube Fitting (SS-810-1-12W)	360 / 14.17	322 / 12.86	W1

1. Other dimensions on previous page

All dimensions are for standard products. For customization of face to face length and/or process connection types other than the ones listed on this page, please consult factory. Note that larger diameter flange process connections are always possible.

Options and Accessories

RHM06L Part Number Option Codes	
H1	Hot oil/steam heating matrix for housing, DN15 PN40
H2	Hot oil/steam heating matrix for housing, ½" ANSI 150 RF
H3	Hot oil/steam heating matrix for housing, ½" ANSI 300 RF
P2	Housing purge connections – ¼" NPT (2 pcs)
SB	Housing in 316 stainless steel
WH	Fully welded/sealed housing
DY	Dye penetrant inspection
XR	X-ray test – PFT, xM0 (flange) types only

NOTE: when specifying a sensor with multiple part code options (i.e. SB and WH), separate each code with a comma in the part string (i.e. ...SB,WH...)

Cable Entry Options (order separately)	
ORHM-E1	½" NPT terminal box cable entry
ORHM-E2	M20 x 1.5 terminal box cable entry
ORHM-E3	¾" NPT terminal box cable entry

Standard cable entry on terminal box is M25 x 1.5

Transmitter Range



Any Rheonik Mass Flow Transmitter model can be combined with any Rheonik Mass Flow Sensor to provide an overall mass flow measurement system to suit any requirement. Rheonik Coriolis transmitters are available in versions specifically designed for process, industrial and OEM applications. Together they offer a tremendous range of options for system designers and end users alike.

See separate data sheet for the features of each transmitter style

About Rheonik

Rheonik has a single purpose: to design and manufacture the very best Coriolis meters available. Our research and engineering resources are dedicated to finding new and better ways to provide cost effective accurate mass flow solutions. Our manufacturing group care for each and every meter we produce from raw materials all the way to shipping and our service and support group are available to help you specify, integrate, start-up and maintain each and every Rheonik meter you have in service. Whether you own just one meter or have hundreds, you will never be just another customer to us. You are our valued business partner.

Need a specific configuration for your plant - don't compromise with a "standard" product from elsewhere that will add extra cost to your installation. If we can't configure it from our extensive product range, our exclusive **AnyPipeFit Commitment** can have your flow sensor customized with any size or type process connection you need.

No matter what control system you use as the backbone in your enterprise, with our **AnyInterface Commitment**, you can be sure that connection and communication will not be a problem. Alongside a wide variety of discrete analog or digital signal connections, we can also provide just about any network/bus interface available (for example: HART, ProfibusDP, ProfiNet, EtherCAT, PowerLink, EtherNet/IP, CAN,) with our RHE4x family of transmitters. Rheonik RHE4X transmitters can connect to your system – no headache and no conversion needed.