

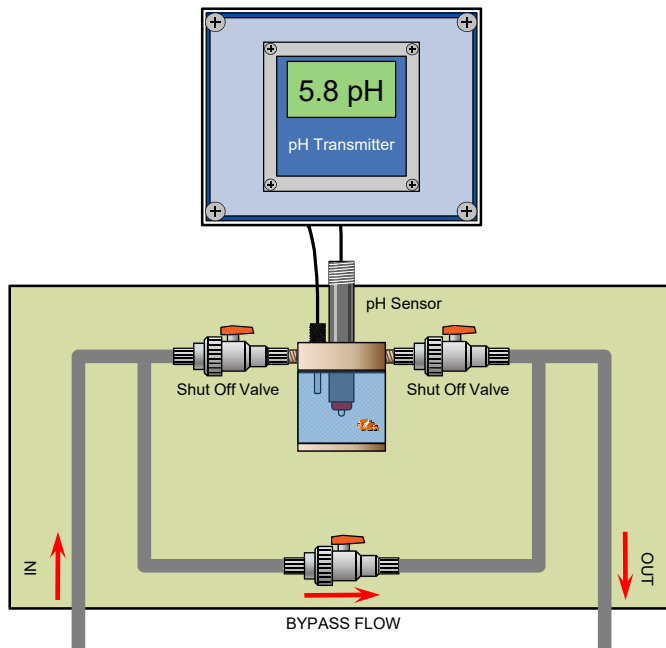

REFEX™ System for Water Treatment pH Measurement

The REFEX Water Treatment pH System is designed to give reliable, continuous real time measurement of water quality in water and waste water treatment systems. Designed to be operated as a side stream, the system is supplied complete with a purpose built flowcell assembly that houses the measurement electrodes.

REFEX pH electrodes are provided. The robust reference sensor uses a highly stable, rapid response, non-porous polymeric interface instead of a traditional porous liquid junction as used by all conventional reference electrodes. The non-porous nature of the electrode interface prevents the loss of electrolyte into the flow stream, preventing the rapid degradation of the measurement and costly frequent replacement of “consumable” probes. REFEX electrodes typically last 5 times longer than conventional electrodes in water treatment applications. The electrode is also highly resistant to fouling and coatings, greatly reducing maintenance overhead and providing high measurement uptime when in service.



Equipment:

- 1 x REFEX EC-2001 pH Combination Electrode
- 1 x LPFC Flow Cell
and
- 1 x Side Stream System
or
- 1 x Immersion/Dip Extension Tube for Open Pit/Channel
- 1 x pH Transmitter

REFEX Helps Improve Coagulation Efficiency

REFEX™
sensors ltd
“The First to Last”



Maintaining pH is vital for the efficiency of coagulation and flocculation in water treatment systems. The ultra-fast measurement response of REFEX electrodes allows tighter control of dosing chemicals, lowering costs both directly and indirectly

Deviations from optimum coagulation conditions (i.e. coagulant chemical dosing rates and pH) can seriously affect treatment performance in water treatment plants. Coagulant chemicals are often sensitive to pH and perform best when pH is maintained within a tight range. Less than optimal conditions can have significant impact on residual coagulant concentration, turbidity, particle counts, NOM (Natural Organic Matter) and micro organisms making the proper control of coagulant dosage and coagulation pH important operational challenges.

Often, turbidity and NOM removal performance is best achieved at pH ranges from 5 to 6, while at pH > 6, NOM removal efficiency lessens significantly and requires higher dosage of coagulant. It is clear that rapid and large variation in raw water quality represents major operational challenges to ensure optimal coagulation conditions suitable to the actual raw water quality are maintained.

REFEX solid state reference electrodes provide instantaneous response to pH change. This very important measurement quality is vital where chemical dosing is required to maintain optimal conditions as slow response can lead to both over- and under-dosing of often expensive correction chemicals - increasing costs directly with greater use of correction chemicals and indirectly by lowering coagulation efficiency.

The slow response of conventional electrodes in correction chemical control systems leads to over-shoot of set points (*Fig. 1*) and therefore greater chemical usage – correction chemicals are needed to correct for the overcorrection!

REFEX reference electrodes provide rapid response because their entire wetted surface is electrochemically active. This helps to prevent pH over-shoot (*Fig. 2*), resulting in significant chemical savings and improved operational efficiency.

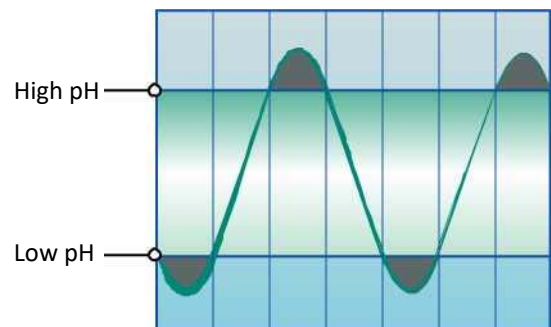

Fig. 1 Conventional Porous Junction pH Sensor Response = “Rollercoaster” = pH Overshoot

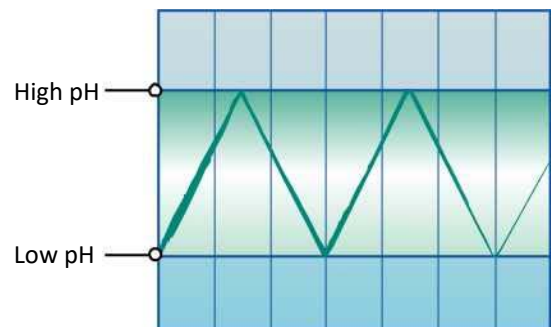

Fig. 2 REFEX Solid State Non Porous pH Sensor Response = “Alpine Peaks” = Tight Control within Setpoints

For more information:
www.southforkinst.com
info@southforkinst.com
T: 925-461-5059



Water Treatment System Specs

REFEX™
sensors ltd
"The First to Last"



EC2001 pH Combination Sensor

pH Range	0 - 12
Temp Range	0 – 100°C
Pressure	20 bar @ 50°C
Reference	<50 kΩ
Eo Zero	pH 7.0 ±15 mV
Impedance	<150 MΩ
Drift	2 mV / Week
Connector	Screw Terminal Ferrules
Cable Length	1, 3, 5 10m (other lengths available)
Part No	EC-3/4"-2001-Pt1000-LE-xM

Refex reference sensors are designed for arduous applications particularly where fouling or poisoning conditions exist. The reference uses a patented highly stable non-porous polymeric interface instead of a traditional porous liquid junction as used by all conventional reference electrodes.



pH Side Stream Assembly

Cell Material	Clear Polypropylene. The cell serves multiple purposes: <ul style="list-style-type: none"> • Reduced flow housing for pH sensor • Sight glass for visual inspection • Buffer cup for verification and calibration
Bypass System	½" PVC piping system to cell complete with Bypass
Valves	3 x PVC ball valves <ul style="list-style-type: none"> • 2 x flow cell isolation • 1 x bypass

For more information:
www.southforkinst.com
info@southforkinst.com
 T: 925-461-5059



EXdip Immersion Accessory for Open Channel/Pit Probe Installation

REFEX™
sensors ltd
"The First to Last"



EXdip Immersion Accessory

Tubing Material:	PP / PVDF or SS
Mounting:	<ul style="list-style-type: none"> • Flange for plate mounting • U-Bolts for rail mounting into open vessels • Chain Suspension Hanger
Length:	Up to 2.5m as standard. Custom lengths available
Part Number:	See EXdip Data Sheet

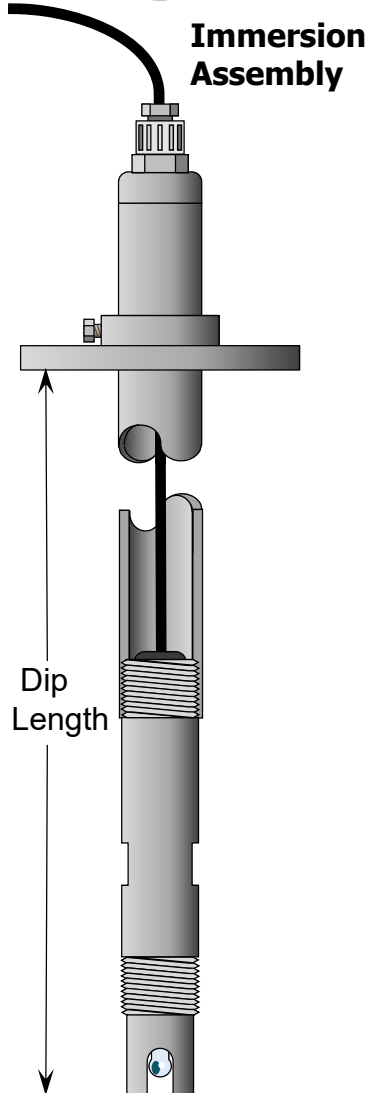
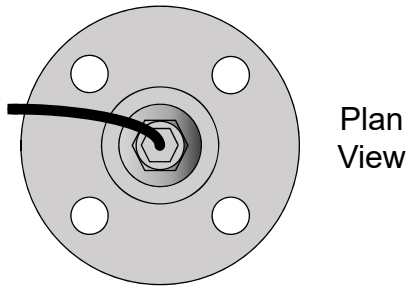

Optional Probe Spray Cleaning

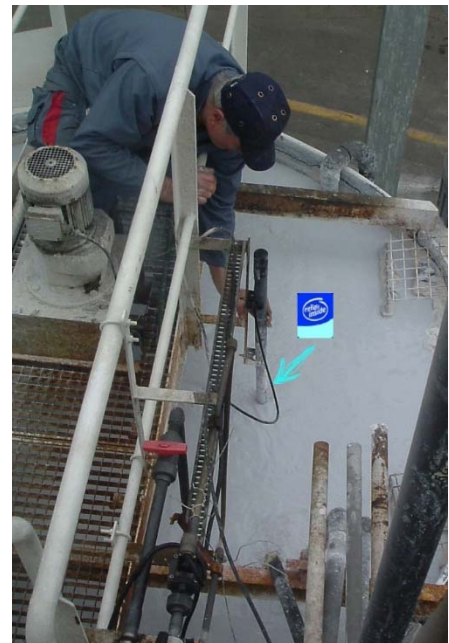
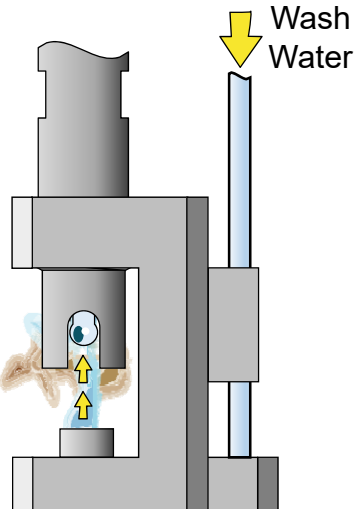

For more information:
www.southforkinst.com
info@southforkinst.com
T: 925-461-5059





Applications: In-Line and Immersion Systems

- Potable Water Applications
- Optimized Coagulation
- Low Ionic Raw Water and Ultra Pure Water (UPW)
- All Oil & Gas Sour Water
- All Petrochemical Process Water
- Chlor-Alkali - Chlorinated and Waste Brines
- Food and Beverage - CIP and SIP
- Industrial Waste Water
- Waste Water Treatment
- Heavy Metal Processes
- Pulp and Paper

Advantages of Reflex Non Porous Electrodes

- Protected Ag/AgCl reference half cell - REFEX barrier/interface prevents all liquid contact/exchange
- Resistant to fouling and poisoning
- Suitable for temperatures between 0...100°C
- Operates in pressures between full vacuum and 20 bar / 290 psi
- Instantaneous response to pH change
- Constant Eo zero - almost maintenance free
- Long electrode life - many times longer than all others
- Compatible with all modern pH instruments with dual high impedance inputs for pH and reference electrodes.
- No diffusion potential errors in low ionic waters
- No electrolyte refilling - sealed for life

For more information:
www.southforkinst.com
info@southforkinst.com
T: 925-461-5059

